

DSE2□HMDA EtherCAT Slave Module MANUAL

Chapter 1: Product Introduction

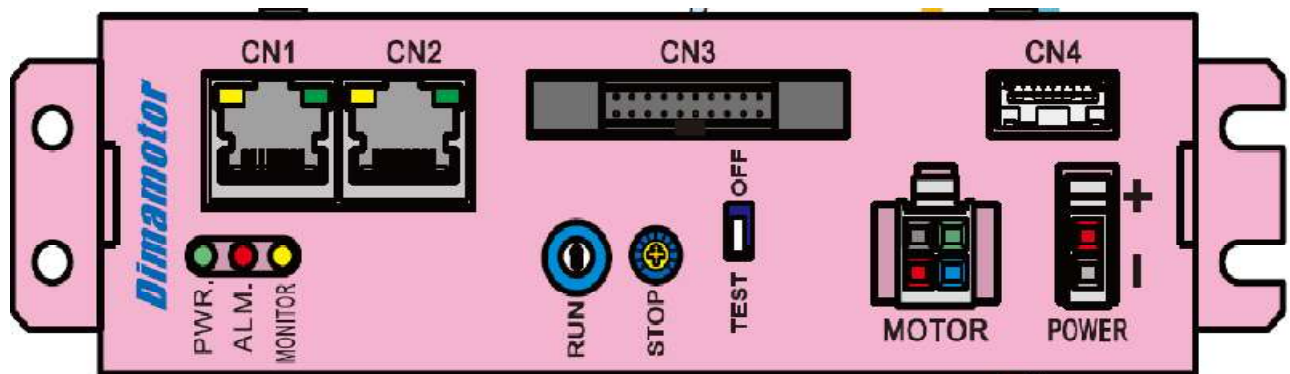

1.1 Hardware Specifications

High Speed Pulse Output

- 2 set of High Speed Pulse output
- Max. output frequency: 500KHz
- Format: CW/CCW

Absolute Encoder Input (CN4)

- 1 set of absolute Encoder Input
- 16-bit multi-turn encoder
- 17-bit single-turn encoder

Digital Input and Output (CN3)

- 4 general inputs and 6 general outputs
- 4 functional inputs and 1 functional output
- 1 H.OFF output
- 3 sets RESOLUTION outputs
- 1 ALARM input

Power Requirements

- DC input range: DC 24V \pm 2V with over-voltage and reversed-voltage protection

EtherCAT Section

- Data transfer medium: Ethernet cable (CAT5e), shield type: S/STP or S/UTP
- Ethernet interface: 2x RJ-45
- Data transfer rate: 100Mbps, full duplex
- Protocol: EtherCAT
- Device profile: CiA 402

- **Size**

- Dimension (mm): 40(W) x 138(L) x 70(H)

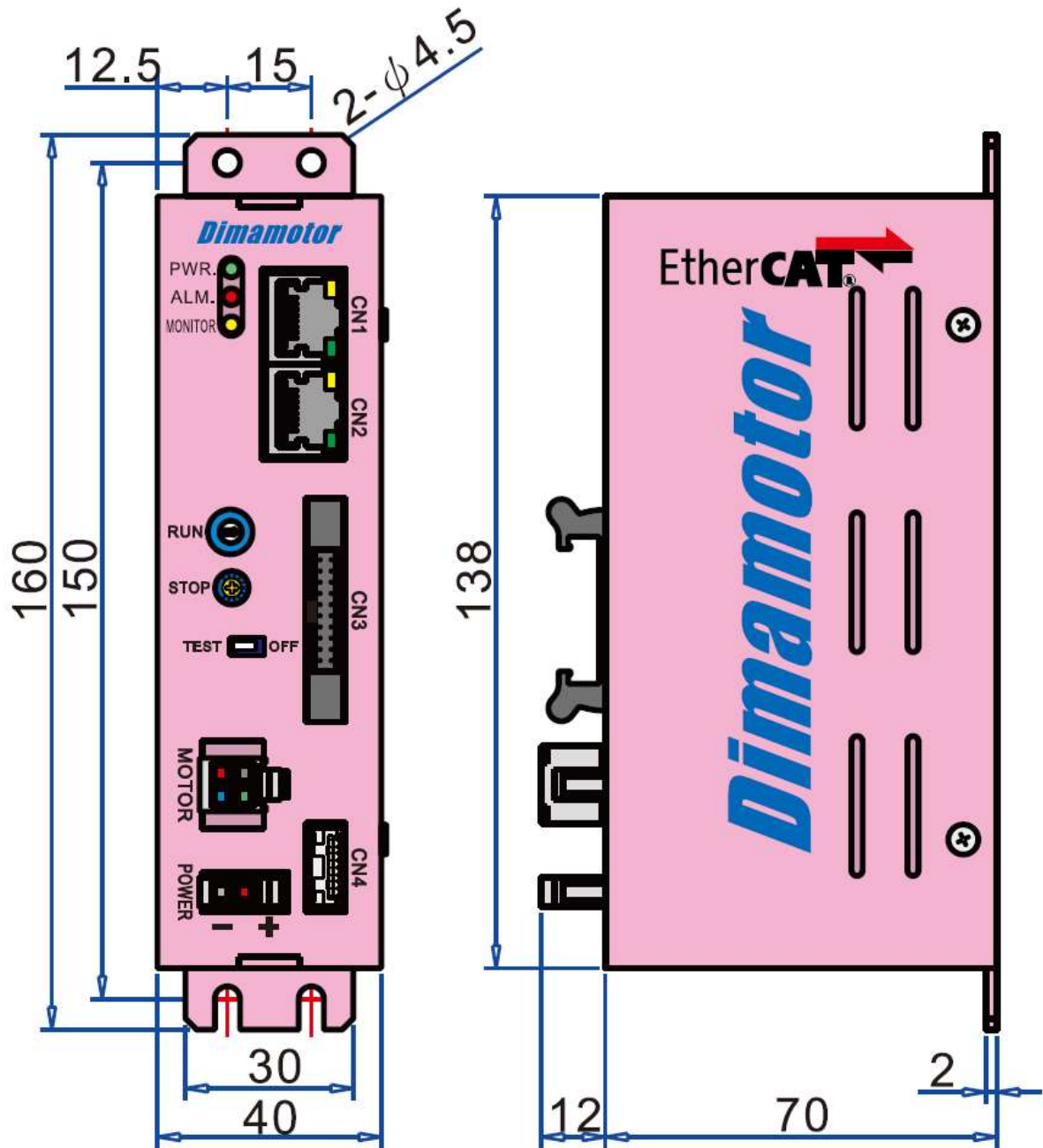

Chapter 2: Connector Pinout Assignments and Wiring Diagrams

2.1 Before You Begin

- Ensure you have a stable, clean working environment.
- Before working on any components, make sure that the power is off.
- Ground yourself before touching any components.
- Static electricity can damage many of the electronic components.

2.2 Locations of the Connectors and LEDs

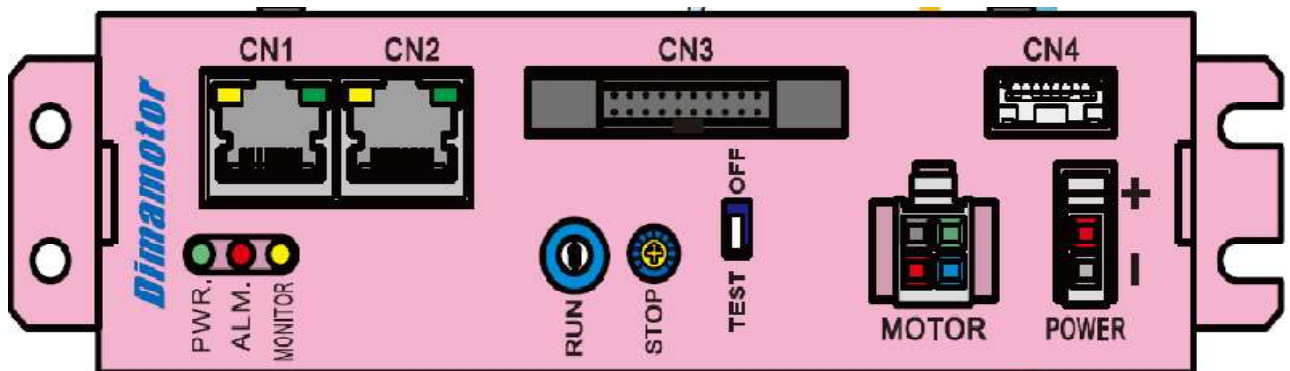

2.3 LED Indicators

PWR.	Power LED	
	ON	Power supply connect to 24 VDC
	OFF	Power supply doesn't connect to 24 VDC

ALARM	ON	ALARM
	OFF	ALARM NG

MONITOR	ON	(A) High-speed pulse current monitoring during flashing (B) Constant bright motor phase loss
	OFF	NO High-speed pulse current monitoring

2.4 ENCODER Female Connector (CN4) and Encoder body Thread

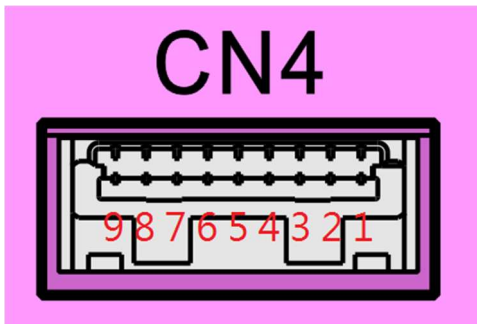

PIN	Driver Thread color	Encoder body Thread color	Battery Box	NAME	TYPE	Definition
1	RED	RED		5VCC	Power	VCC 5V Output
2	BLACK	BLACK		GND	Power	Ground 0V
3	WHITE	GREEN		RS485 A	IN	Serial Data Signal
4	WHITE BLACK	YELLOW		RS485 B	IN	Serial Data Signal
5	GREEN	WHITE		POWER SUPPLY	OUT	Battery Thread
6	GREEN BLACK	BROWN		GROUND	OUT	Battery Thread
7.	YELLOW		RED	POWER SUPPLY	Power	Battery Box
8.	YELLOW BLACK		BLACK	GROUND	Power	Battery Box
9	Heat shrink			FG	Power	Frame Groun

2.5 Power Supply Connector

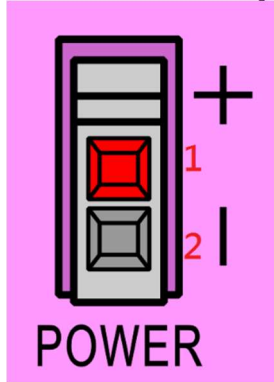

PIN	NAME	TYPE	Definition
1	+24V	PWR	DC Power Supply
2	GND	PWR	DC 0V

2.6 MOTOR Connector

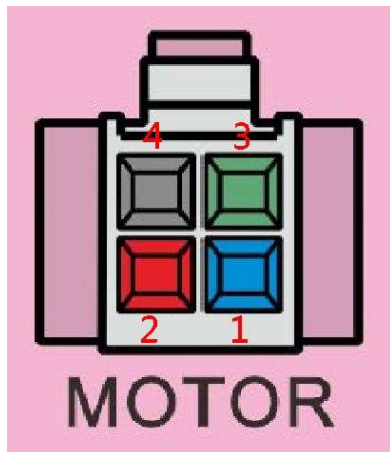

PIN	NAME	Definition	Line color
4	A	A Phase	Black
3	/A	/A Phase	Green
2	B	B Phase	Red
1	/B	/B Phase	Blue

2.7 Digital Input and Output

2.7.1 Input

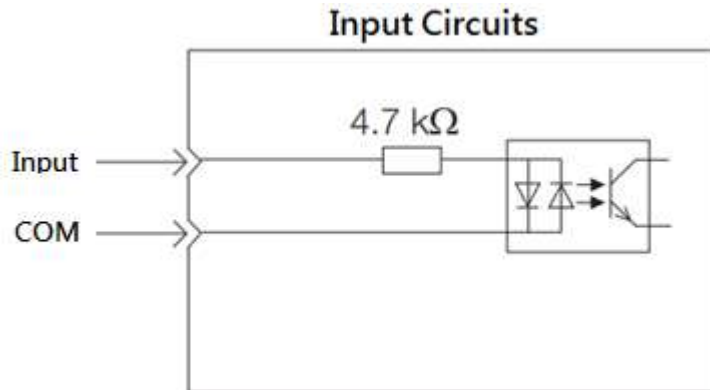

- Current range: 1mA~10mA
- Voltage range: 5V OR 24 V

2.7.1.1 General purpose input (CN3)

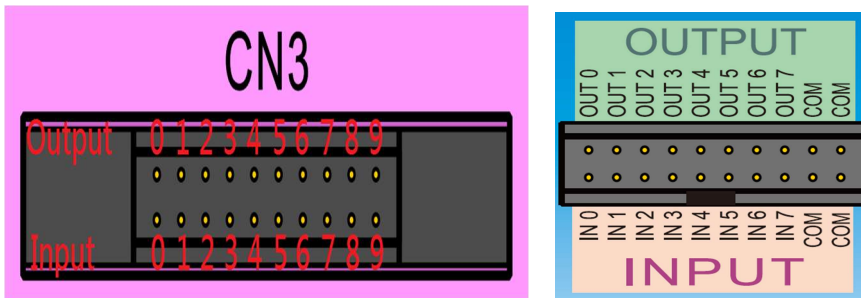

PIN	NAME	TYPE	Definition
0	IN0	IN	General purpose input 0
1	IN1	IN	General purpose input 1
2	IN2	IN	General purpose input 2
3	IN3	IN	General purpose input 3
4	IN4	IN	Abort
5	IN5	IN	Auto-run start
6	IN6	IN	Auto-run select 0
7	IN7	IN	Auto-run select 1
8、9	COM	PWR	0V or 5V or 24 V

2.7.2 output

Output Circuits

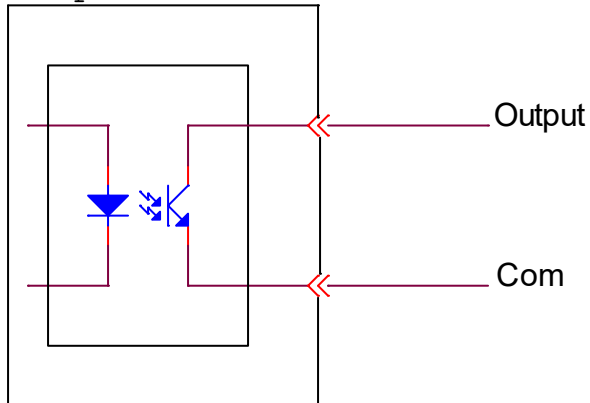

- **Single max current : 10mA**
- **Voltage range: 5V OR 24 V**

※Please add appropriate external current limiting resistors to avoid loop burnout due to overvoltage.

External current limiting resistor calculation formula: $R = V_{in}/10mA$

2.7.2.1 General purpose output (CN3)

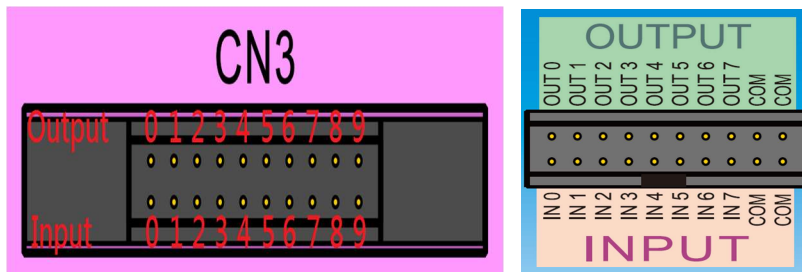

PIN	NAM E	TYPE	Definition
0	OUT0	OUT	General purpose output 0
1	OUT1	OUT	General purpose output 1
2	OUT2	OUT	General purpose output 2
3	OUT3	OUT	General purpose output 3
4	OUT4	OUT	General purpose output 4
5	OUT5	OUT	General purpose output 5
6	OUT6	OUT	IS AUTORUN
7			Reserved

8、9	COM	PWR	0V
-----	-----	-----	----

2.8-1 How to use the current adjustment knob

(1) Motor running current setting :

1. Use the [RUN] knob: adjust the range

DS22HMDA : 0.34~2A / phase ; DS23HMDA : 0.5~3A / phase ◦

2. DS22HMDA It is set at the factory [2] , output current is 0.53A/phase ;
, which is about 27% of the rated current.

DS23HMDA It is set at the factory [A] , output current is 2.35A/phase ;
, which is about 79% of the rated current.



※ Set the drive RUN current value so that it does not exceed the rated current of the motor coil.

[RUN] knob [scale / current value] comparison table

DSE22HMDA				DSE23HMDA			
Scale	Running current (A/phase)	Scale	Running current (A/phase)	Scale	Running current (A/phase)	Scale	Running current (A/phase)
0	0.34	8	1.3	0	0.5	8	1.95
1	0.42	9	1.44	1	0.63	9	2.16
2	0.53	A	1.6	2	0.79	A	2.35
3	0.65	B	1.7	3	0.98	B	2.54
4	0.79	C	1.82	4	1.18	C	2.73
5	0.92	D	1.96	5	1.37	D	2.93
6	1.05	E	2	6	1.57	E	3
7	1.18	F	2	7	1.77	F	3

DS22HMDA :

Frame [20] Set the maximum current value to 0.5A , set the [RUN] knob to 2 scale

Frame [28] Set the maximum current value to 1.5A , set the [RUN] knob to 9 scales

Frame [42] Set the maximum current value to 2A , set the [RUN] knob to set F scales

DS23HMDA :

Frame [60] Set the maximum current value to 3A , set the [RUN] knob to set F scale

(2) Motor stop current setting:

Adjust the [STOP] knob scale to set the motor stop current. The STOP current drop rate ranges from 22 to 100%.

[STOP] knob [scale / current drop rate] comparison table

Scale	Current drop rate (%)	Scale	Current drop rate (%)
0	21	6	64
1	23	7	68
2	37	8	71
3	47	9	73
4	55	10	75
5	60		

* Motor stop current = motor running [RUN] current x current drop rate

2.8-2 Dip switch Test self-test function

OFF/TEST	Dip switch	
	TEST	The motor runs at about 2 pps (to detect if the drive itself is normal) and rotates clockwise
	OFF	Stop the self-test function. When operating normally, cut to the OFF side.

2.8 Product system block diagram

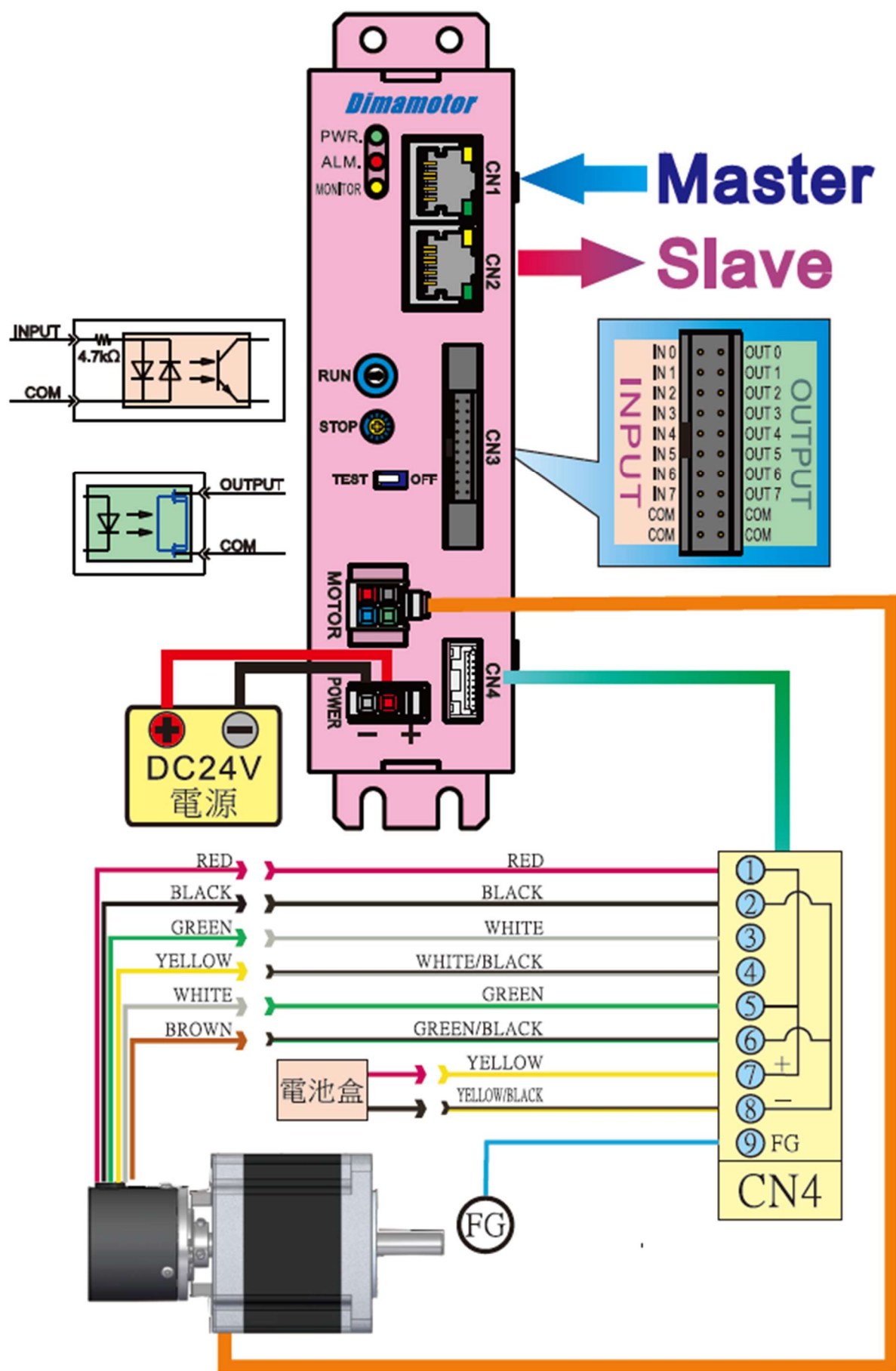

2.9 Product related parts

- 2.9.1 : Encoder cable: ECLA-05 (5M) x 1 pcs
- 2.9.2 : DC power cable : DPL-030(30cm)x 1 pcs
- 2.9.3 : I/O connect : IOC-1 x 1 pcs
- 2.9.4 : motor connect : MTC-1 x 1 set

Chapter 3: Operation

3.1 EtherCAT Slave Information (ESI)

According to EtherCAT standard document ETG.2000, every EtherCAT slave must be delivered an ESI file (a XML format to describe EtherCAT slave information) for the EtherCAT Master. The ESI file contains the necessary settings for the communication.

Chapter 4: Object Dictionary

4.1 Architecture of Object Dictionary

Index (Hex)	Meaning
0x1000~0x1FFF	CoE communication objects
0x2000~0x5FFF	Manufacturer Specific Objects
0x6000~0x7FFF	CANOpen CiA 402 Profile Specific Objects

4.2 Object Type and Attributes

Code	C/C++ type	Description	Size (byte)	Range
USINT	uint8_t	unsigned byte	1	0~255
UINT	uint16_t	unsigned short integer	2	0~65535
UDINT	uint32_t	unsigned long integer	4	0~4294967295
SINT	int8_t	signed byte	1	-128~127
INT	int16_t	signed short integer	2	-32768~32767

DINT	int32_t	signed long integer	4	-2147483648~ 2147483647
STRING	-	string value	-	-

Attribute	Description
RO	This object is only for read.
WO	This object is only for write.
RW	This object is for read and write.

4.3 Object Dictionary List

Object Dictionaries		Refer to
General Objects	Device Type (1000h)	4.4
	Manufacturer Device Name (1008h)	4.4
	Manufacturer Hardware Version (1009h)	4.4
	Manufacturer Software Version (100Ah)	4.4
	Identity Object (1018h)	4.4
PDO Mapping Objects	Receive PDO Mapping (1600h to 1602h)	4.4
	Transmit PDO Mapping (1A00h to 1A02h)	4.4
Sync Manager Communication Objects	Sync Manager Communication Type (1C00h)	4.4
	Sync Manager Synchronization (1C32h, 1C33h)	4.4
	Sync Error Setting (10F1h)	4.4
Manufacturer Specific Objects	Pulse Mode (2000h)	4.5
	Acceleration Divisor(2001h)	4.5
	Resolution(2002h)	4.5
	H.OFF(2003h)	4.5
	Encoder Setting(2004h)	4.5
	Alarm(2005h)	4.5
	Autorun Paramater 0(2030h)	4.5
	Autorun Paramater 1(2031h)	4.5
	Autorun Paramater 2(2032h)	4.5
	Autorun Paramater 3(2033h)	4.5
	Encoder Value(2038h)	4.5

	Autorun enable(203Ah)	4.5
	Steps per revolution(203Bh)	4.5
	Reset Multi-turn Value(203Ch)	4.5
Device Control	Controlword (6040h)	4.6
	Statusword (6041h)	4.6
	Quick Stop Option Code (605Ah)	4.6
	Shutdown Option Code (605Bh)	4.6
	Disable Operation Option Code (605Ch)	4.6
	Halt Option Code (605Dh)	4.6
	Fault Reaction Option Code (605Eh)	4.6
	Modes of Operation (6060h)	4.6
	Modes of Operation Display (6061h)	4.6
	Supported Drive Modes (6502h)	4.6
Profile Position Mode/ Cyclic Synchronous Position Mode/ Cyclic Synchronous Velocity Mode	Position Actual Value (6064h)	4.6
	Velocity Actual Value (606Ch)	4.6
	Target Position (607Ah)	4.6
	Software Position Limit (607Dh)	4.6
	Max. Profile Velocity (607Fh)	4.6
	Profile Acceleration (6083h)	4.6
	Profile Deceleration (6084h)	4.6
	Quick Stop Deceleration (6085h)	4.6
	Target Velocity (60FFh)	4.6
	Interpolation time period (60C2h)	4.6
Homing Mode	Home Offset (607Ch)	4.6
	Homing Method (6098h)	4.6
	Homing Speeds (6099h)	4.6
	Homing Acceleration (609Ah)	4.6
Digital Inputs/Outputs	Digital Inputs (60FDh)	4.6
	Digital Outputs (60FEh)	4.6

4.4 CoE Communication Objects (0x1000~0x1FFF)

Device type

Index	Sub	Name	Data Type	Access	PDO	Default
-------	-----	------	-----------	--------	-----	---------

					Mapping	Value
0x1000	00	Device type	UDINT	RO	N	0x40192

- Bit0~15: 0x192 (DS402 device)
- Bit16~23: 0x04 (Stepper Drive)

Device name

Index	Sub	Name	Data Type	Access	PDO Mapping	Default Value
0x1008	00	Device name	STRING	RO	N	DIMA402

Hardware version

Index	Sub	Name	Data Type	Access	PDO Mapping	Default Value
0x1009	00	Hardware version	STRING	RO	N	0

Software version

Index	Sub	Name	Data Type	Access	PDO Mapping	Default Value
0x100a	00	Software version	STRING	RO	N	0

Identity

Index	Sub	Name	Data Type	Access	PDO Mapping	Default Value
0x1018	00	Number of entries	USINT	RO	N	4
	01	Vendor ID	UDINT	RO	N	0x00000BC4
	02	Product code	UDINT	RO	N	0
	03	Revision	UDINT	RO	N	1
	04	Serial number	UDINT	RO	N	0

Error Settings

Index	Sub	Name	Data Type	Access	PDO Mapping	Default Value
0x10F1	00	Number of entries	USINT	RO	N	2
	01	Local Error Reaction	Reserved	-	-	-
	02	Sync Error Counter Limit	UINT	RW	N	4

• 0x10F1:02 Sync Error Counter Limit

In DC mode, if the local error counter reaches the limit, the EtherCAT state machine will change to SAFEOP state. The local error counter is set to 0 when the state machine changing to OP state. If the slave miss an SM2 event between two Sync0 events, the local error counter increases by 3; otherwise, the counter decreases by 1.

CSP/CSV RxPDO

Index	Sub	Name	Data Type	Access	PDO Mapping	Default Value
0x1600	00	Number of objects in this PDO	USINT	RO	N	6
	01	Mapping entry 1	UDINT	RO	N	0x60400010
	02	Mapping entry 2	UDINT	RO	N	0x607A0020
	03	Mapping entry 3	UDINT	RO	N	0x60FF0020
	04	Mapping entry 4	UDINT	RO	N	0x60600008
	05	Mapping entry 5	UDINT	RO	N	0x00000008
	06	Mapping entry 6	UDINT	RO	N	0x60FE0020

- 0x1600:01 The 1st RxPDO entry: 0x6040:00 (Control word)
- 0x1600:02 The 2nd RxPDO entry: 0x607A:00 (Target position)
- 0x1600:03 The 3rd RxPDO entry: 0x60FF:00 (Target velocity)
- 0x1600:04 The 4th RxPDO entry: 0x6060:00 (Mode of operation)
- 0x1600:05 The 5th RxPDO entry: padding byte
- 0x1600:06 The 6th RxPDO entry: 0x60FE:00 (Digital output)

CSP RxPDO

Index	Sub	Name	Data Type	Access	PDO Mapping	Default Value
0x1601	00	Number of objects in this PDO	USINT	RO	N	3
	01	Mapping entry 1	UDINT	RO	N	0x60400010
	02	Mapping entry 2	UDINT	RO	N	0x607A0020
	03	Mapping entry 3	UDINT	RO	N	0x60FE0020

- 0x1601:01 The 1st RxPDO entry: 0x6040:00 (Control word of Axis 0)
- 0x1601:02 The 2nd RxPDO entry: 0x607A:00 (Target position of Axis 0)
- 0x1601:03 The 3rd RxPDO entry: 0x60FE:00 (Digital outputs of channel 0 to 7)

CSV RxPDO

Index	Sub	Name	Data Type	Access	PDO Mapping	Default Value
0x1602	00	Number of objects in this PDO	USINT	RO	N	3
	01	Mapping entry 1	UDINT	RO	N	0x60400010
	02	Mapping entry 2	UDINT	RO	N	0x60FF0020
	03	Mapping entry 3	UDINT	RO	N	0x60FE0020

- 0x1602:01 The 1st RxPDO entry: 0x6040:00 (Control word)
- 0x1602:02 The 2nd RxPDO entry: 0x60FF:00 (Target velocity)
- 0x1602:03 The 3rd RxPDO entry: 0x60FE:00 (Digital outputs of channel 0 to 7)

CSP/CSV TxPDO

Index	Sub	Name	Data Type	Access	PDO Mapping	Default Value
0x1A00	00	Number of objects in this PDO	USINT	RO	N	6
	01	Mapping entry 1	UDINT	RO	N	0x60410010

	02	Mapping entry 2	UDINT	RO	N	0x60640020
	03	Mapping entry 3	UDINT	RO	N	0x606C0020
	04	Mapping entry 4	UDINT	RO	N	0x60610008
	05	Mapping entry 5	UDINT	RO	N	0x00000008
	06	Mapping entry 6	UDINT	RO	N	0x60FD0020

- 0x1A00:01 The 1st TxPDO entry: 0x6041:00 (Status word)
- 0x1A00:02 The 2nd TxPDO entry: 0x6064:00 (Actual position)
- 0x1A00:03 The 3rd TxPDO entry: 0x606C:00 (Actual velocity)
- 0x1A00:04 The 4th TxPDO entry: 0x6061:00 (Mode of operation display)
- 0x1A00:05 The 5th TxPDO entry: padding byte
- 0x1A00:06 The 6th TxPDO entry: 0x60FD:00 (Digital input)

CSP TxPDO

Index	Sub	Name	Data Type	Access	PDO Mapping	Default Value
0x1a01	00	Number of objects in this PDO	USINT	RO	N	3
	01	Mapping entry 1	UDINT	RO	N	0x60410010
	02	Mapping entry 2	UDINT	RO	N	0x60640020
	03	Mapping entry 3	UDINT	RO	N	0x60FD0020

- 0x1A01:01 The 1st TxPDO entry: 0x6041:00 (Status word)
- 0x1A01:02 The 2nd TxPDO entry: 0x6064:00 (Target position)
- 0x1A01:03 The 3rd TxPDO entry: 0x60FD:00 (Digital inputs of channel 0 to 7)

CSV TxPDO

Index	Sub	Name	Data Type	Access	PDO Mapping	Default Value
0x1a02	00	Number of objects in this PDO	USINT	RO	N	3
	01	Mapping entry 1	UDINT	RO	N	0x60410010

	02	Mapping entry 2	UDINT	RO	N	0x60640020
	03	Mapping entry 3	UDINT	RO	N	0x60FD0020

- 0x1A02:01 The 1st TxPDO entry: 0x6041:00 (Status word)
- 0x1A02:02 The 2nd TxPDO entry: 0x6064:00 (Target position)
- 0x1A02:03 The 3rd TxPDO entry: 0x60FD:00 (Digital inputs of channel 0 to 7)

Sync Manager Type

Index	Sub	Name	Data Type	Access	PDO Mapping	Default Value
0x1C00	00	Number of used Sync Manager channels	USINT	RO	N	4
	01	Communication type sync manager 0	USINT	RO	N	1
	02	Communication type sync manager 1	USINT	RO	N	2
	03	Communication type sync manager 2	USINT	RO	N	3
	04	Communication type sync manager 3	USINT	RO	N	4

- 0x1C00:01 Communication type of SM0: 1 (mailbox out)
- 0x1C00:02 Communication type of SM1: 2 (mailbox in)
- 0x1C00:03 Communication type of SM2: 3 (process data out)
- 0x1C00:04 Communication type of SM3: 4 (process data in)

RxPDO assign

Index	Sub	Name	Data Type	Access	PDO Mapping	Default Value
0x1C12	00	Number of assigned PDOs	USINT	RW*	N	1
	01	PDO Mapping object index of assigned RxPDO	UINT	RW*	N	0x1602

***Writable in only pre-operation state**

• 0x1C12:00 Number of RxPDO: 0 to 1

Set to 1 for one-axis mode

• 0x1C12:01 1st RxPDO: 0x1600 to 0x1602

Set to 0x1600 for CSP/CSV mode, 0x1601 for CSP mode, or 0x1602 for CSV mode.

Setup Procedure of RxPDO Mapping:

1. Set object 0x1C12:00 to 0.
2. Set object 0x1C12:01 or 0x1C12:02 if necessary.
3. Set object 0x1C12:00 to 1 for one-axis

TxPDO assign

Index	Sub	Name	Data Type	Access	PDO Mapping	Default Value
0x1C13	00	Number of assigned PDOs	USINT	RW*	N	1
	01	PDO Mapping object index of assigned TxPDO	UINT	RW*	N	0x1A02

***Writable in only pre-operation state**

• 0x1C13:00 Number of TxPDO: 0 to 1

Set to 1 for one-axis mode

• 0x1C13:01 1st TxPDO: 0x1A00 to 0x1A02

Set to 0x1A00 for CSP/CSV mode, 0x1A01 for CSP mode, or 0x1A02 for CSV mode.

Setup Procedure of TxPDO Mapping:

1. Set object 0x1C13:00 to 0.
2. Set object 0x1C13:01 or 0x1C13:02 if necessary.
3. Set object 0x1C13:00 to 1 for one-axis mode

SM output parameter

Index	Sub	Name	Data Type	Access	PDO Mapping	Default Value
0x1C32	00	Number of Synchronization Parameters	USINT	RO	N	32
	01	Synchronization Type	UINT	RO	N	0
	02	Cycle Time	UDINT	RO	N	0
	03	Reserved	-	-	-	-
	04	Reserved	-	-	-	-
	05	Minimum Cycle Time	UDINT	RO	N	250000
	06	Reserved	-	-	-	-
	07	Reserved	-	-	-	-
	08	Reserved	-	-	-	-
	09	Delay Time	UDINT	RO	N	0
	0a	Sync0 Cycle Time	UDINT	RO	N	0
	0b	SM-Event Missed	UINT	RO	N	0
	0c	Reserved	-	-	-	-
	0d~1f	Reserved	-	-	-	-
	20	Sync Error	BOOL	RO	N	0

- 0x1C32:01 Synchronization Type: 0 for free-run mode, 1 for SM-sync mode, or 2 for DC-sync mode.
- 0x1C32:02 Cycle Time: Time between Sync0 events [ns]
- 0x1C32:05 Minimum Cycle Time: 250000 [ns]
- 0x1C32:0B SM-Event Missed: Referred to object 0x10F1
- 0x1C32:20 Sync Error: 1 for sync error occurs.

SM input parameter

Index	Sub	Name	Data Type	Access	PDO Mapping	Default Value
0x1C33	00	Number of Synchronization Parameters	uint8	RO	N	32
	01	Synchronization Type	UINT	RO	N	0
	02	Cycle Time	UDINT	RO	N	0
	03	Shift time	Reserved	-	-	-
	04	Synchronization Types supported	Reserved	-	-	-
	05	Minimum Cycle Time	UDINT	RO	N	250000
	06	Calc and Copy Time	Reserved	-	-	-
	07	Reserved	Reserved	-	-	-
	08	Get Cycle Time	uint16	RO	N	0
	09	Delay Time	UDINT	RO	N	0
	0a	Sync0 Cycle Time	UDINT	RO	N	0
	0b	SM-Event Missed	UINT	RO	N	0
	0c	Cycle Time Too Small	UINT	RO	N	0
	0d	Shift Time Too Short	Reserved	-	-	-
	0e~1f	-	Reserved	-	-	-
	20	Sync Error	BOOL	RO	N	0

- 0x1C33:01 Synchronization Type: 0 for free-run mode, 1 for SM-sync mode, or 2 for DC-sync mode.
- 0x1C33:02 Cycle Time: Time between Sync0 events [ns]
- 0x1C33:05 Minimum Cycle Time: 250000 [ns]
- 0x1C33:0B SM-Event Missed: Referred to object 0x10F1
- 0x1C33:20 Sync Error: 1 for sync error occurs.

4.5 Manufacturer Specific Objects (0x2000~0x2FFF)

Pulse Mode

Index	Sub	Name	Data Type	Access	PDO Mapping	Default Value
0x2000	00	Pulse Mode	USINT	RW	N	1

• 0x2000:00 Pulse Mode of Axis 0: 1

1: CW/CCW mode

Note1: This object is loaded from and written to data flash.

Note2: This object is read only while servo on.

Acceleration Divisor

Index	Sub	Name	Data Type	Access	PDO Mapping	Default Value
0x2001	00	Acceleration Divisor	UDINT	RW	N	1000

• 0x2001:00 Acceleration Divisor: 1 to 0xFFFFFFFF

The divisor of profile acceleration, homing acceleration, and quick stop acceleration.

Note: This object is loaded from and written to data flash.

Resolution

Index	Sub	Name	Data Type	Access	PDO Mapping	Default Value
0x2002	00	Resolution	USINT	RW	N	1

• 0x2002:00 Resolution 1 output: 1 : 1000 PPR

Note: This object is loaded from and written to data flash.

Resolution

Index	Sub	Name	Data Type	Access	PDO Mapping	Default Value
0x2002	00	Resolution	USINT	RW	N	2

• 0x2002:00 Resolution output: 2 to 6

2: Resolution output 800 PPR

3: Resolution output 1600 PPR

4: Resolution output 3200 PPR

5: Resolution output 6400 PPR

6: Resolution output 12800 PPR

H.OFF

Index	Sub	Name	Data Type	Access	PDO Mapping	Default Value
0x2003	00	H.OFF	USINT	RW	N	0

- 0x2003:00 H.OFF output: 0 to 1
0: H.OFF NG
1: H.OFF ON

Encoder Setting

Index	Sub	Name	Data Type	Access	PDO Mapping	Default Value
0x2004	00	Encoder Setting	USINT	RW	N	3

- 0x2004:00 Encoder Setting: 0 to 3
0: Encoder is not connected
1: X4 encoder mode
2: X2 encoder mode
3: X1 encoder mode

Note1: This object is loaded from and written to data flash.

Note2: This object is read only while servo on.

Alarm

Index	Sub	Name	Data Type	Access	PDO Mapping	Default Value
0x2005	00	Alarm	USINT	RO	N	0

- 0x2005:00 Alarm input: 0 to 1

Autorun Paramater 0

Index	Sub	Name	Data Type	Access	PDO Mapping	Default Value
-------	-----	------	-----------	--------	-------------	---------------

0x2030	00	Autorun Parameter	USINT	RO	N	8
	01	Multi-turn	UINT	RW	N	0
	02	Single-turn	UDINT	RW	N	0
	03	Acceleration	UDINT	RW	N	500
	04	Deceleration	UDINT	RW	N	500
	05	Buffer	UDINT	RW	N	1200
	06	Max speed	UDINT	RW	N	1000
	07	Autorun Speed 1	UDINT	RW	N	100
	08	Autorun Speed 2	UDINT	RW	N	10

• The following graph shows the meaning of these parameters.

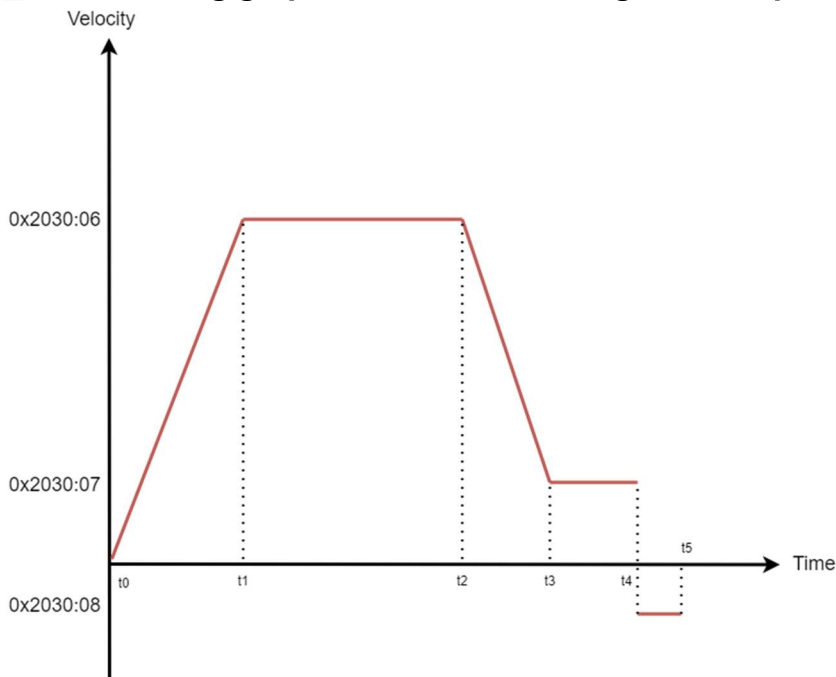

Phase i (t0 to t1): The motor accelerates until the speed reaches *Object[2030:06]* (unit: *step/sec*). The acceleration value is *Object[2030:03]*(unit: *step/sec²*).

Phase ii (t1 to t2): The motor rotates at constant speed until the distance from current position to the target is under *Object[2030:05]*(unit: *step*). The multi-turn value of target is *Object[2030:01]*, and the single-turn value is *Object[2030:02]*.

Phase iii (t2 to t3): The motor decelerates until the speed reaches *Object*[2030:07] (unit: *step/sec*). The deceleration value is *Object*[2030:04](unit: *step/sec²*).

Phase iv (t3 to t4): The motor rotates at constant speed until the current position reaches the target.

Phase v (t4 to t5): If the current position exceeds the target at the end of Phase iv, the motor rotates backward. The speed value is *Object*[2030:08] (unit: *step/sec*).

Note: This object is loaded from and written to data flash.

Autorun Paramater 1

Index	Sub	Name	Data Type	Access	PDO Mapping	Default Value
0x2031	00	Autorun Parameter	USINT	RO	N	8
	01	Multi-turn	UINT	RW	N	1
	02	Single-turn	UDINT	RW	N	0
	03	Acceleration	UDINT	RW	N	500
	04	Deceleration	UDINT	RW	N	500
	05	Buffer	UDINT	RW	N	1200
	06	Max speed	UDINT	RW	N	1000
	07	Autorun Speed 1	UDINT	RW	N	100
	08	Autorun Speed 2	UDINT	RW	N	10

• See Object 0x2030.

Note: This object is loaded from and written to data flash.

Autorun Paramater 2

Index	Sub	Name	Data Type	Access	PDO Mapping	Default Value
0x2032	00	Autorun Parameter	USINT	RO	N	8
	01	Multi-turn	UINT	RW	N	2
	02	Single-turn	UDINT	RW	N	0
	03	Acceleration	UDINT	RW	N	500
	04	Deceleration	UDINT	RW	N	500
	05	Buffer	UDINT	RW	N	1200
	06	Max speed	UDINT	RW	N	1000
	07	Autorun Speed 1	UDINT	RW	N	100
	08	Autorun Speed 2	UDINT	RW	N	10

• See Object 0x2030.

Note: This object is loaded from and written to data flash.

Autorun Paramater 3

Index	Sub	Name	Data Type	Access	PDO Mapping	Default Value
0x2033	00	Autorun Parameter	USINT	RO	N	8
	01	Multi-turn	UINT	RW	N	3
	02	Single-turn	UDINT	RW	N	0
	03	Acceleration	UDINT	RW	N	500
	04	Deceleration	UDINT	RW	N	500
	05	Buffer	UDINT	RW	N	1200
	06	Max speed	UDINT	RW	N	1000

	07	Autorun Speed 1	UDINT	RW	N	100
	08	Autorun Speed 2	UDINT	RW	N	10

• See Object 0x2030.

Note: This object is loaded from and written to data flash.

Encoder Value

Index	Sub	Name	Data Type	Access	PDO Mapping	Default Value
0x2038	00	Encoder Value	USINT	RO	N	8
	01	Multi-turn	UINT	RO	N	
	02	Single-turn	UDINT	RO	N	
	03	Encoder status	USINT	RO	N	
	04	Encoder alarm code	USINT	RO	N	
	05	Reserved	UDINT	RO	N	

• 0x2038:01 Encoder multi-turn value: 0 to 65535

• 0x2038:02 Encoder single-turn value: 0 to 131071

• 0x2038:03 Encoder status:

Bit 0 to 3: Reserved.

Bit 4: "1" ,when error occurs. i.e., encoder counting error. (Mostly due to magnetic reasons)

Bit 5: "1" , Logic 1-OR of Multi-turn error, Battery error and Battery alarm is transmitted.

Bit 6 to 7: Reserved.

• 0x2038:04 Encoder alarm code:

Bit 0: when the rotation speed exceeding the upper limitation, this bit is set to high (1).

Bit 2: Counting Error (CE), mostly caused by magnetic error.

Bit 3: Counting overflow, mostly caused logic "1" is transmitted when the multi-turn counter is overflow. The multi-turn counter continues to operate as a cyclic counter of 0~ 65,535.

Bit 5: Multi-turn error, Logic "1" is transmitted, when reversals and counting errors occur.

Bit 6: Logic "1" is generated when the external battery voltage is $3.32 \pm 0.25V$ or less during main power-off.

Bit 7: Battery error: Logic "1" is transmitted, when the external battery voltage is $3.47 \pm 0.1 V$ or less during main power-on.

Autorun enable

Index	Sub	Name	Data Type	Access	PDO Mapping	Default Value
0x203A	00	Autorun enable	USINT	RW	N	1

• 0x203A:00 Autorun enable

1: Auto-run mode is enabled.

0: Auto-run mode is disabled.

Steps per revolution

Index	Sub	Name	Data Type	Access	PDO Mapping	Default Value
0x203B	00	Steps per rev	UDINT	RW	N	1000

• 0x203B:00 Steps per revolution

Note1: This object is loaded from and written to data flash.

Note2: Writing this object takes effect after restart.

Reset Multi-turn Value

Index	Sub	Name	Data Type	Access	PDO Mapping	Default Value
-------	-----	------	-----------	--------	-------------	---------------

0x203C	00	Reset multi-turn value	USINT	RW	N	0
--------	----	------------------------	-------	----	---	---

- Write 1: Start reset multi-turn value procedure.
- Write 0: No effect.
- Read 1: Reset procedure is in progress.
- Read 0: Reset procedure is completed or not started.

4.6 CANOpen CiA 402 Profile Specific Objects(0x6000~0x7FFF)

Control Word

Index	Sub	Name	Data Type	Access	PDO Mapping	Default Value
0x6040	00	Control Word	UINT	RW	Y	0

- 0x6040:00 Control Word:

Bit 0 to 3 and bit 7: for the controlling command of the drive state

Command	bit 7	bit 3	bit 2	bit 1	bit 0
Shutdown	0	-	1	1	0
Switch on	0	0	1	1	1
Disable voltage	0	-	-	0	-
Quick stop	0	-	0	1	0
Disable operation	0	0	1	1	1
Enable operation	0	1	1	1	1

Fault reset

0→1

No ready to switch on

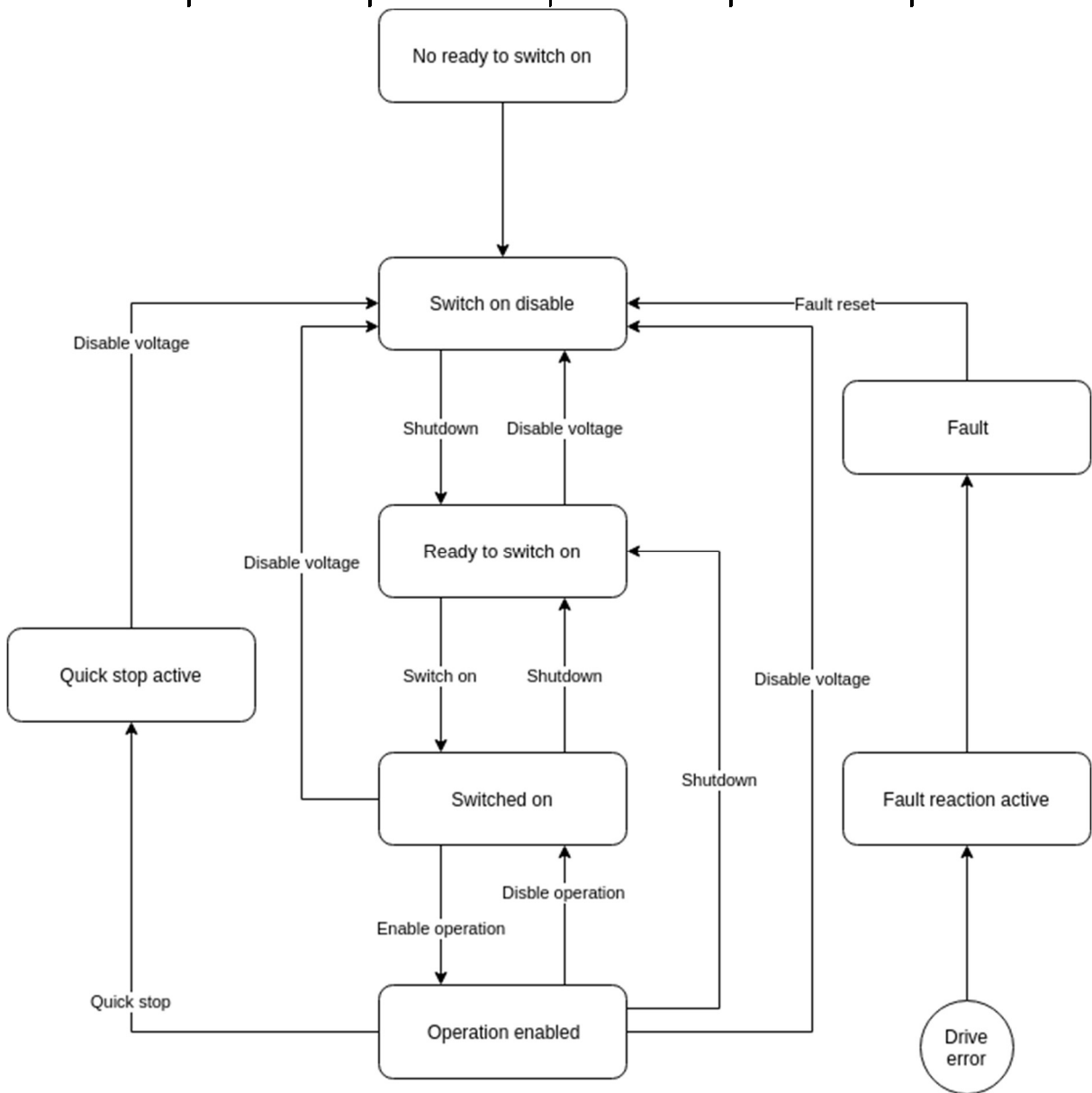

DS402 state machine

Bit 4, 5, 6, 8 and 9: for the controlling of Homing mode

Bit	Function	Value	Description
4	Homing operation start	0	Stop homing procedure
		1	Start or continue homing procedure
5	-	0	Reserved
6	-	0	Reserved
8	Halt	0	Do not halt homing procedure
		1	Halt homing procedure
9	-	0	Reserved

Bit 4, 5, 6, 8 and 9: for the controlling of CSP/CSV/PV mode

Bit	Function	Value	Description
4	-	0	Reserved
5	-	0	Reserved
6	-	0	Reserved
8	Halt	0	Do not halt CSP/CSV/PV procedure
		1	Halt CSP/CSV/PV procedure
9	-	0	Reserved

Bit 10 to 15: reserved. These bits should be set to 0s.

Status Word

Index	Sub	Name	Data Type	Access	PDO Mapping	Default Value
0x6041	00	Status Word	UINT	RO	Y	*(See below)

• 0x6041:00 Status Word of Axis 0:

Bit 0 to 3 and bit 5 to 6: for the current state of the drive

Command	bit 6	bit 5	bit 3	bit 2	bit 1	bit 0
Not ready to switch on	0	0	0	0	0	0
Switch on disabled	1	0	0	0	0	0
Ready to switch on	0	1	0	0	0	1
Switched on	0	1	0	0	1	1
Operation enabled	0	1	0	1	1	1
Quick stop active	0	0	0	1	1	1
Fault reaction active	0	0	1	1	1	1
Fault	0	0	1	0	0	0

Bit 10, 12 and 13: for Homing mode

Bit	Status	Value	Description
10	Target reached	0	Halt (Bit 8 in Controlword) = 0: Target not reached Halt (Bit 8 in Controlword) = 1: Axis decelerates
		1	Halt (Bit 8 in Controlword) = 0: Target reached Halt (Bit 8 in Controlword) = 1: Velocity of axis is 0
12	Homing attained	0	Homing mode not yet complete
		1	Homing mode complete successfully
13	-	-	Reserved

Bit 10, 12 and 13: for Profile velocity mode

Bit	Status	Value	Description
10	Target reached	0	Halt (Bit 8 in Controlword) = 0: Target not reached Halt (Bit 8 in Controlword) = 1: Axis decelerates
		1	Halt (Bit 8 in Controlword) = 0: Target reached Halt (Bit 8 in Controlword) = 1: Velocity of axis is 0
12	-	-	Reserved
13	-	-	Reserved

Quickstop Option Code

Index	Sub	Name	Data Type	Access	PDO Mapping	Default Value
0x605a	00	Quickstop Option Code	INT	RW	N	2

- **0x605A:00 Quickstop Option Code of Axis 0:**
- 0:** Disable driver function (turns the servo OFF)
- 1:** Slow down on slow down ramp and stay in Operation Enabled. The slow down deceleration is defined as the following object.
 - **Cyclic Position, Cyclic Velocity mode:** Object 0x6084
 - **Homing mode:** Object 0x609A
- 2:** Slow down on quick stop ramp and stay in Operation Enabled.
- Others:** Reserve.

Shutdown Option Code

Index	Sub	Name	Data Type	Access	PDO Mapping	Default Value
0x605b	00	Shutdown Option Code	INT	RW	N	0

- **0x605B:00 Shutdown Option Code:**
- 0:** Disable driver function (turns the servo OFF)
- 1:** Slow down on slow down ramp and stay in Operation Enabled. The slow down deceleration is defined as the following object.
 - **Cyclic Position, Cyclic Velocity mode:** Object 0x6084
 - **Homing mode:** Object 0x609A
- Others:** Reserved.

Disable Operation Option Code

Index	Sub	Name	Data Type	Access	PDO Mapping	Default Value
0x605c	00	Disable Operation Option Code	INT	RW	N	1

• **0x605C:00 Disable Operation Option Code:**

0: Disable driver function (turns the servo OFF)

1: Slow down on slow down ramp and stay in Operation Enabled. The slow down deceleration is defined as the following object.

- Cyclic Position, Cyclic Velocity mode: Object 0x6084

- Homing mode: Object 0x609A

Others: Reserved.

Halt Option Code

Index	Sub	Name	Data Type	Access	PDO Mapping	Default Value
0x605d	00	Halt Option Code	INT	RW	N	1

• **0x605D:00 Halt Option Code:**

0: Disable driver function (turns the servo OFF)

1: Slow down on slow down ramp and stay in Operation Enabled. The slow down deceleration is defined as the following object.

- Cyclic Position, Cyclic Velocity mode: Object 0x6084

- Homing mode: Object 0x609A

2: Slow down on quick stop ramp and stay in Operation Enabled.

Others: Reserved.

Fault Reaction Code

Index	Sub	Name	Data Type	Access	PDO Mapping	Default Value
0x605e	00	Fault Reaction Code	INT	RW	N	2

• **0x605E:00 Fault Reaction Code:**

0: Disable driver function (turns the servo OFF)

1: Slow down on slow down ramp and stay in Operation Enabled. The slow down deceleration is defined as the following object.

- Cyclic Position, Cyclic Velocity mode: Object 0x6084

- Homing mode: Object 0x609A

2: Slow down on quick stop ramp and stay in Operation Enabled.

Others: Reserved.

Modes of Operation

Index	Sub	Name	Data Type	Access	PDO Mapping	Default Value
0x6060	00	Modes of Operation	SINT	RW	Y	0

• 0x6060:00 Modes of Operation:

3: Profile velocity mode.

6: Homing mode.

8: Cyclic synchronous position mode.

9: Cyclic synchronous velocity mode.

Others: Reserved.

Modes of Operation Display

Index	Sub	Name	Data Type	Access	PDO Mapping	Default Value
0x6061	00	Modes of Operation Display	SINT	RO	Y	0

• 0x6061:00 Modes of Operation Display:

3: Profile velocity mode.

5: Homing mode.

8: Cyclic synchronous position mode.

9: Cyclic synchronous velocity mode.

Others: Reserved.

Position Actual Value

Index	Sub	Name	Data Type	Access	PDO Mapping	Default Value
0x6064	00	Position Actual Value	DINT	RO	Y	0

• 0x6064:00 Position Actual Value of Axis 0: -2147483648 to 2147483647 [*pulse*]

Velocity Actual Value

Index	Sub	Name	Data Type	Access	PDO Mapping	Default Value
0x606c	00	Velocity Actual Value	DINT	RO	Y	0

- 0x606C:00 Velocity Actual Value of Axis 0: –2147483648 to 2147483647

$$\text{Actual velocity} = \frac{\text{Object}[0x60 :00]}{\text{cycle time}} \text{ [pulse/sec]}$$

Target Position

Index	Sub	Name	Data Type	Access	PDO Mapping	Default Value
0x607a	00	Target Position	DINT	RW	Y	0

- 0x607A:00 Target Position: –2147483648 to 2147483647 [pulse]

Homing Offset

Index	Sub	Name	Data Type	Access	PDO Mapping	Default Value
0x607c	00	Homing Offset	UDINT	RW	N	0

- 0x607C:00 Homing Offset: –2147483648 to 2147483647 [pulse]

Software Position Limit

Index	Sub	Name	Data Type	Access	PDO Mapping	Default Value
0x607d	00	SubIndex 000	USINT	RO	N	2
	01	Min position limit	DINT	RW	N	-20000000 00
	02	Max position limit	DINT	RW	N	20000000 00

- 0x607D:01 Minimum position limit: –2147483648 to 2147483647 [pulse]

- 0x607D:02 Maximum position limit: –2147483648 to 2147483647 [pulse]

If $\text{Object}[0x607D:01] \geq \text{Object}[0x607D:02]$, the software limit is disabled.

Max Profile Velocity

Index	Sub	Name	Data Type	Access	PDO Mapping	Default Value
0x607f	00	Max Profile Velocity	UDINT	RW	N	500

- 0x607F:00 Max Profile Velocity: 1 to 4294967295

$$\text{Max profile velocity} = \frac{\text{Object}[0x607F:00]}{\text{cycle time}} \text{ [pulse/sec]}$$

Profile Accelerat

Index	Sub	Name	Data Type	Access	PDO Mapping	Default Value
0x6083	00	Profile Acceleration	UDINT	RW	N	1

- **0x6083:00 Profile Acceleration: 1 to 4294967295**

$$\text{Profile Acceleration} = \frac{\text{Object}[0x6083:00]/\text{Object}[0x2001:00]}{\text{cycle time}} \text{ [pulse/sec}^2\text{]}$$

Profile Deceleration

Index	Sub	Name	Data Type	Access	PDO Mapping	Default Value
0x6084	00	Profile Deceleration	UDINT	RW	N	1

- **0x6084:00 Profile Deceleration: 1 to 4294967295**

$$\text{Profile Deceleration} = \frac{\text{Object}[0x6084:00]/\text{Object}[0x2001:00]}{\text{cycle time}} \text{ [pulse/sec}^2\text{]}$$

Quick stop Deceleration

Index	Sub	Name	Data Type	Access	PDO Mapping	Default Value
0x6085	00	Quick stop Deceleration	DINT	RW	N	10

- **0x6085:00 Quick stop acceleration: 1 to 4294967295**

$$\text{Quick stop acceleration} = \frac{\text{Object}[0x6085:00]/\text{Object}[0x2001:00]}{\text{cycle time}} \text{ [pulse/sec}^2\text{]}$$

Homing Method

Index	Sub	Name	Data Type	Access	PDO Mapping	Default Value
0x6098	00	Homing Method	USINT	RW	N	0

- 0x6098:00 Home Method of Axis 0: 33 to 35.

Value	Definition	Description
33,34	Homing on index pulse	
35	Homing on the current position	In this method, the current position shall be taken to be the home position.

Homing Speeds

Index	Sub	Name	Data Type	Access	PDO Mapping	Default Value
0x6099	00	Number of entries	USINT	RO	N	2
	01	Switch Speed	UDINT	RW	N	1
	02	Zero Speed	UDINT	RW	N	1

- 0x6099:01 Switch Speed: 1 to 4294967295

$$\text{Finding limit switch speed} = \frac{\text{Object}[0x6099:01]}{\text{cycle time}} \text{ [pulse/sec]}$$

- 0x6099:02 Zero Speed: 1 to 4294967295

$$\text{Finding Zero switch speed} = \frac{\text{Object}[0x6099:02]}{\text{cycle time}} \text{ [pulse/sec]}$$

Homing Acceleration

Index	Sub	Name	Data Type	Access	PDO Mapping	Default Value
0x609a	00	Homing Acceleration	UDINT	RW	N	1

- 0x609A:00 Homing acceleration: 1 to 4294967295

$$\text{Homing acceleration} = \frac{\text{Object}[0x609A:00]/\text{Object}[0x2001:00]}{\text{cycle time}} [\text{pulse}/\text{sec}^2]$$

Interpolation Time

Index	Sub	Name	Data Type	Access	PDO Mapping	Default Value
0x60c2	00	Highest sub-index supported	USINT	RO	N	2
	01	Interpolation period	USINT	RW	N	1
	02	Interpolation Index	SINT	RW	N	-3

- 0x60C2:01 Interpolation Period: 1 to 250

- 0x60C2:02 Interpolation Index: -6 to -3

$$\text{Interpolation time} = \text{Object}[0x60C2:01] \times 10^{\text{Object}[0x60C2:02]} [\text{sec}]$$

This object must be set properly in free run mode.

Digital Inputs

Index	Sub	Name	Data Type	Access	PDO Mapping	Default Value
0x60fd	00	Digital Inputs	UDINT	RO	Y	-

- 0x60FD:00 Digital Inputs Channel 0 to 7:

Bit 0 to 7: digital inputs channel 0 to 7.

Bit 8 to 31: reserved.

Digital Outputs

Index	Sub	Name	Data Type	Access	PDO Mapping	Default Value
-------	-----	------	-----------	--------	-------------	---------------

0x60fe	00	Digital Outputs	UDINT	RW	Y	0
--------	----	-----------------	-------	----	---	---

• 0x60FE:00 Digital Outputs Channel 0 to 7:

Bit 0 to 7: digital outputs channel 0 to 7.

Bit 8 to 31: reserved.

Target Velocity

Index	Sub	Name	Data Type	Access	PDO Mapping	Default Value
0x60ff	00	Target Velocity	DINT	RW	Y	0

• 0x60FF:00 Target Velocity: 0 to 4294967295

$$Target\ velocity = \frac{Object[0x60FF:00]}{cycle\ time} [pulse/sec]$$

Supported Drive Modes

Index	Sub	Name	Data Type	Access	PDO Mapping	Default Value
0x6502	00	Supported Drive Modes	UDINT	RO	N	*(See below)

• 0x6502:00 Supported Drive Modes:

For CSV/CSP PDO mapping, PV/CSV/CSP/Homing modes are supported.

(value=0x1a4)

For CSP PDO mapping, CSP/Homing modes are supported. (value=0xa0)

For CSV PDO mapping, PV/CSV/Homing modes are supported.